

Mytek Protools HD DIO Card

User Manual

ver. 1.1 / Oct 2010

© Mytek 2006

This manual may be updated

Download the newest version at:

<http://www.mytekdigital.com/documents library/>

For technical support, technical tips and support check:

<http://www.mytekdigital.com>

or contact Mytek tech support at:

highend@mytekdigital.com

or at:

tel. (646)-613 1822

fax.(212)-202 5331

Mytek
151 Lafayette Street
New York NY 10013
USA

Digidesign Pro Tools ® is a trademark of Digidesign/Avid

Content

| | |
|-----------------------------------|----|
| Content..... | 3 |
| Introduction..... | 4 |
| Before You Begin..... | 4 |
| Quick Start..... | 5 |
| Card Installation..... | 7 |
| Connecting Clock Signal Line..... | 12 |
| Input Connection..... | 14 |
| Signal Routing..... | 15 |
| Launch and Configuration..... | 17 |
| Typical Configurations..... | 19 |
| Software Update..... | 26 |

Introduction

The Mytek Protools-HD DIO Card is a physical card that plugs into the back of the Mytek 8X192 ADDA converter.

With this card installed the Mytek 8X192 ADDA can be directly connected to the Core, Process or Accel interface cards of Digidesign Pro Tools HD® systems.

The card may be installed by the user as described further in the manual. The 8X192ADDA with the card installed will be recognized by Protools HD® software as an emulated HD192 interface.

Before You Begin

Before connecting the DIO-HD card check if the most current firmware (version 4.5.3 or later) is installed in the 8X192 converter. To verify the version locate the firmware chip on the main converter board, or please contact Mytek for additional assistance.

(If necessary contact Mytek to request appropriate firmware.)

Quick Start

1. DIO-HD card installation

Remove the top cover from the converter, unscrew *DIOCARD1* slot plate (first slot from the right while looking at the rear panel) and install the DIO-HD card using provided screws. Double check that all the connector pins match properly with the pins of the connector on the main converter board.

Remember to turn off power, and disconnect power and signal cables while working with the top cover removed.

2. Connecting the card to Protools HD ® system

The Pro Tools card must be connected to the *Primary Port* of the DIO-HD card. A maximum of two converters (which can be of different brands) can be connected to each Protools card. In the case of more than one converter, the second one should be daisy chained from the *Expansion Port* of the first converter to the *Primary Port* of the second.

3. Connecting the clock signal

The first converter in the Pro Tools system must operate on internal clock and is the system clock master. We recommend always making Mytek the master as it incorporates a superior clock generator with multiple wordclock outputs. When a 192 I/O Digidesign interface is connected in the slave configuration, WCK on the front panel of Mytek converter must be set to *FS/4*.

Turn down the amplifier and speakers connected to the computer while launching the Pro Tools application.

4. Hardware Setup Configuration

Choose *Setup > Hardware Setup* and check sampling frequency, clock signal (should be set to *Internal*) and confirm *Input* and *Output* interfaces are present. Every converter in the menu should be *Set to Default*

5. Routing configuration within converters

The Mytek 8X192 ADDA *SOURCE TO DIGITAL OUT* defines sources of audio signals that are sent from the converter to the ProTools system and all other digital outputs (all digital outputs are simultaneous). *SOURCE TO ANALOG OUT* defines sources of audio signals that are transmitted to the DAC in the converter.

Remember that 8x192 ADDA converter has eight channels. Selecting channels 9-16 as audio sources will result in no signal (digital silence).

6. I/O signal configuration

In *Setup > I/O Setup* you can assign signal sources to interfaces.

7. Input selection – start of recording

Choose preconfigured inputs and outputs in Pro Tools, test record, and then playback of selected audio tracks.

Card Installation

Only a single Protools-HD DIO Card can be installed in one converter. A different format card can be installed in the second slot. The HD DIO card must be installed in the DIOCARD1 slot, which is first from the right at the converter's rear panel.

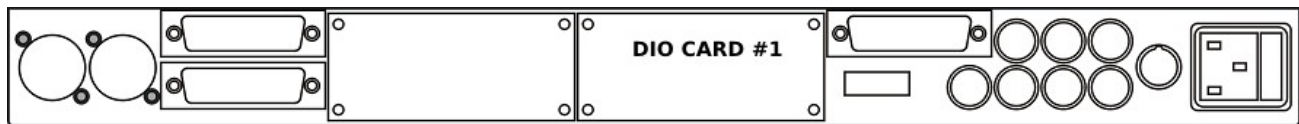

8x192 ADDA converter's rear panel

WARNING!

Remember to follow basic safety rules about handling of electronic devices while opening the converter:

- ✓ keep your hands dry,
- ✓ **turn off power and detach power and signal cables while working with the top cover removed.**

To install DIO-HD card:

1. Find the DIOCARD1 expansion slot at the mainboard's layout
2. Check if the power cord and all signal and clock lines are disconnected.

Before you install the card in the converter, check if converter's firmware supports DIO-HD card (version v.4.5.3 or later). If not, contact your Mytek to request current version.

3. Remove top cover.

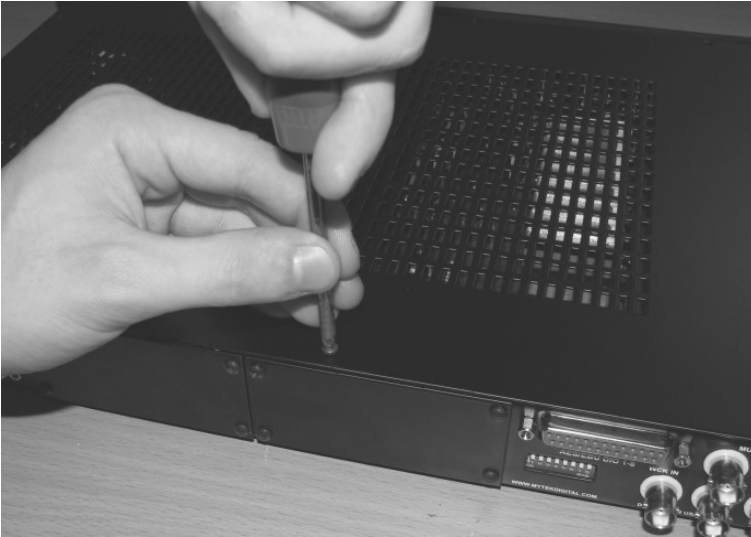

4. Locate the DIOCARD1 expansion slot on the mainboard.

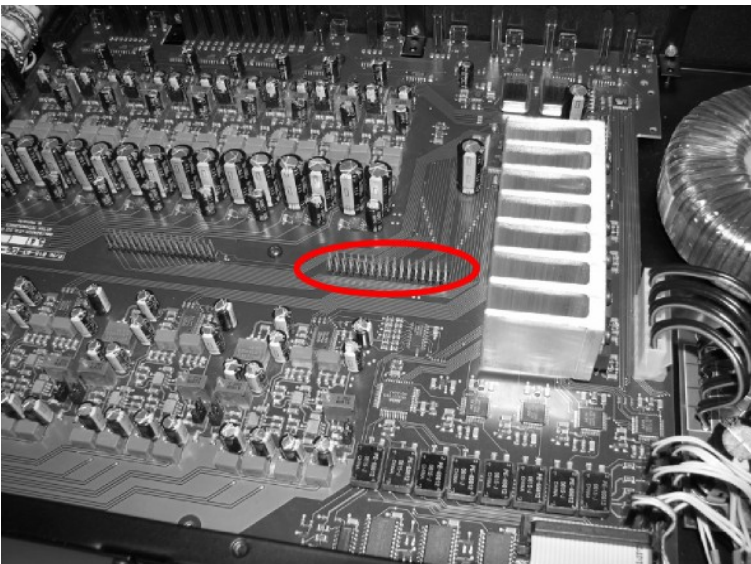

5. Unscrew cover plate of DIOCARD1 slot from the rear panel.

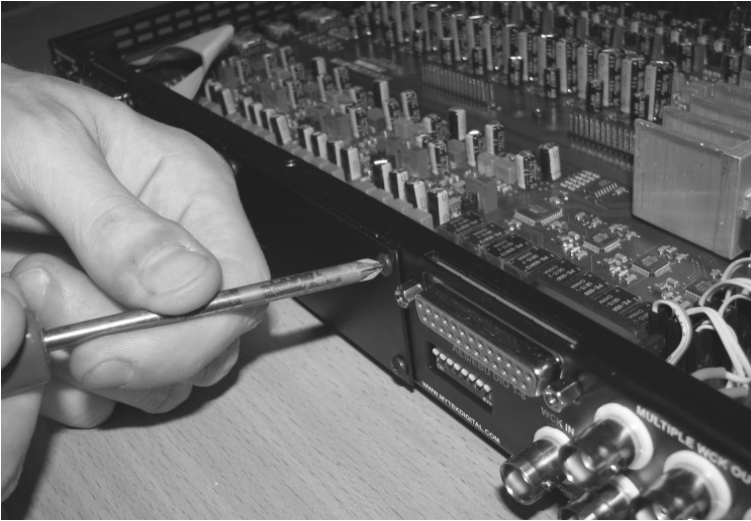

6. Partially insert the card from the back of the converter.

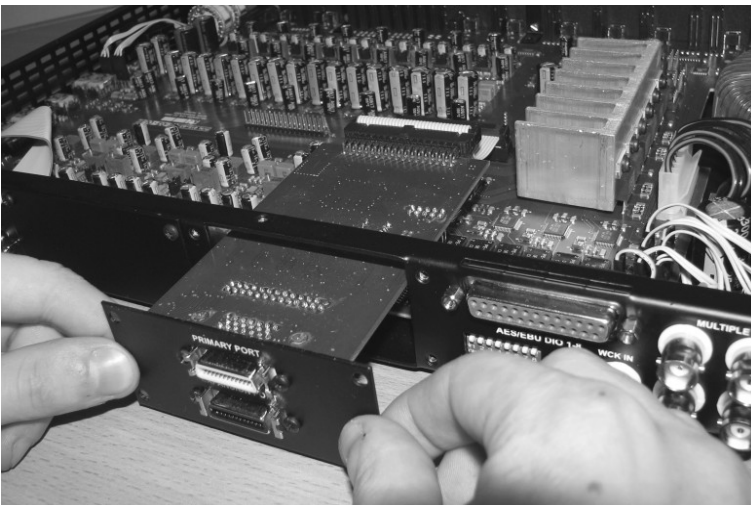

7. Attach card ribbon cable to DIOCARD1 connector on the mainboard.

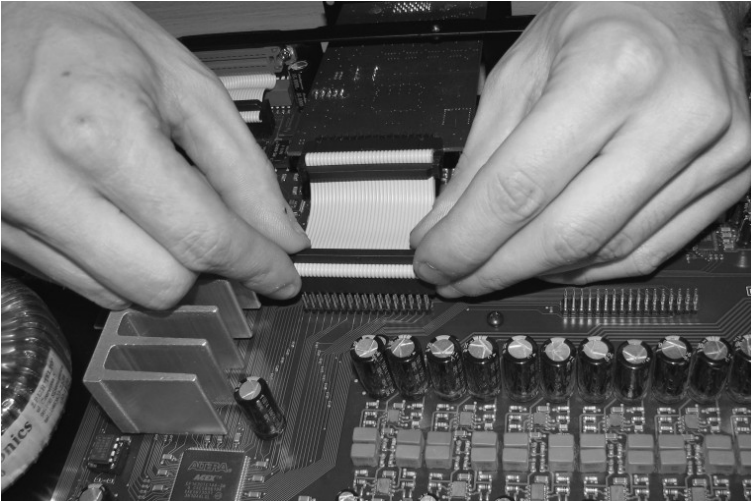

8. Gently push the card inside and secure it using four screws

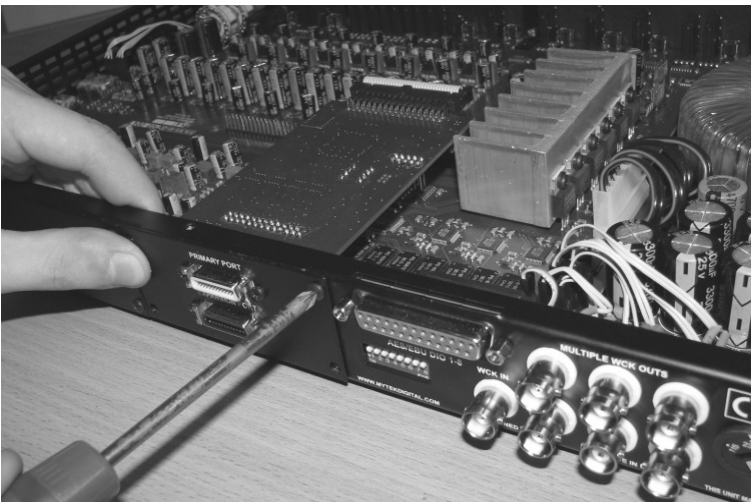

9. Screw in converter top cover.

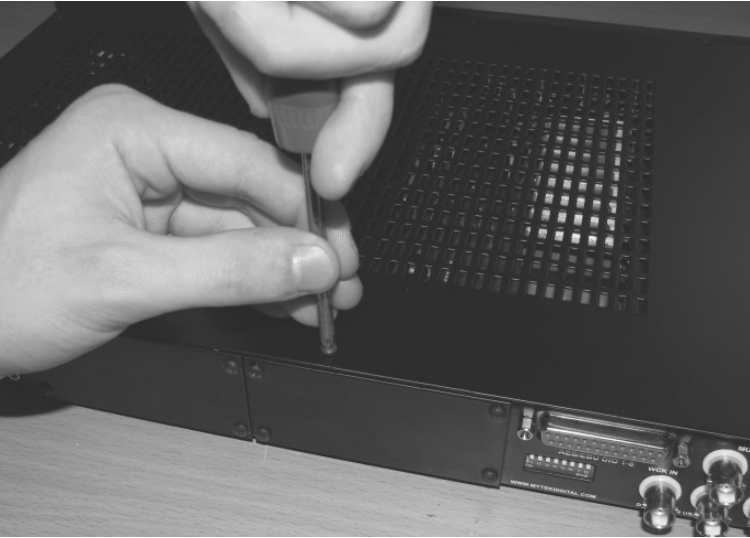

10. Connect power and signal lines.

11. Turn the converter on.

After boot up (which takes approx 20 sec) converter will switch to regular mode, and Protools-HD DIO Card (DIOCARD1) can now be selected as signal source.

Connecting Clock Signal Line

Single converter

If a single converter is used in the system, choosing internal clock is the best solution. If external clock is used for synchronization, *SAMPLE RATE* must be set to *EXT*. To do this, press and hold *EXT CLOCK SOURCE* switch.

Regardless of synchronization source, choose in Pro Tools software: *Setup > Hardware Setup* and select *Internal* on the *Clock Source* tab.

Master 8x192 ADDA converter's front panel



Clock source is typically internal, choose external only if you must use it for systemic reasons.

Check if the selected sampling frequency of the converter (FS) matches the sampling frequency in Pro Tools. If FS is double or quadruple of external clocks frequency, *WCK* option must be set to *FS/4*. *FS/4* is the default setting and must be used whenever multiple Digidesign I/O units are used in addition to master 8X192ADDA.

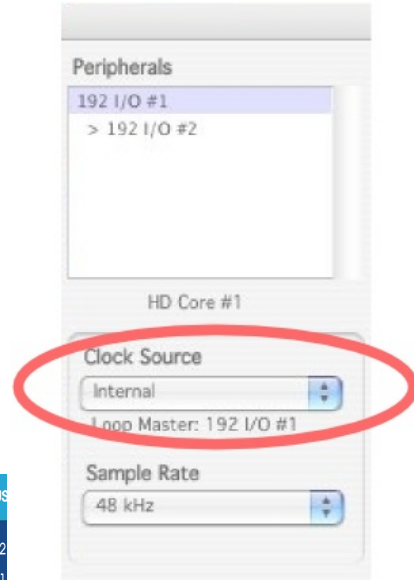

Setup > Hardware Setup

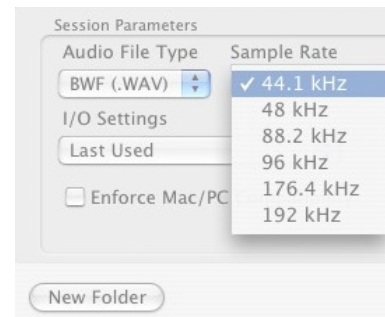

File > New Session

Multiple converters

A Protools HD system can accept up to two converters connected to each card. Various brands can be mixed as long as they are all capable of emulating the Digidesign HD192 I/O interface. If multiple converters are used, one serves as a source of the clock signal (*Master*), with the rest of the devices receiving it (*Slave*).

Our recommended setup is to use the Mytek 8X192ADDA as the clock source feeding all other converters from multiple wordclock outputs to all slave devices in a star configuration.

8X192 ADDA converter has 6 clock outputs. Clock signal originates from the very precise CX797 module. Because of that 8X192 ADDA converter is the best clock signal source in the majority of multiple devices configurations

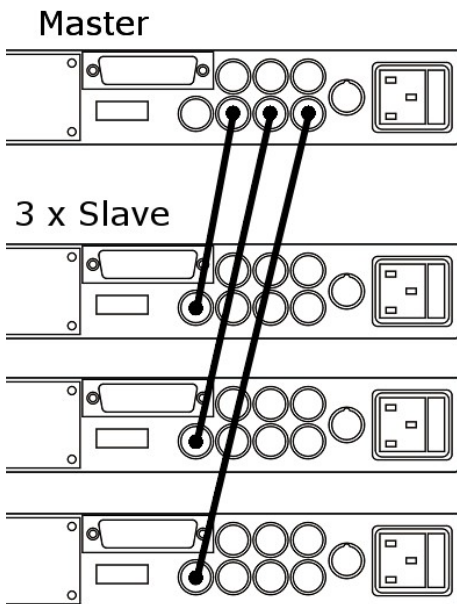

Wordclock connections in a Protools HD system with 3 Mytek 8X192 ADDAs

In system with multiple units, double check that the configuration of clock signal lines, synchronization sources and sampling frequency's of all converters in the system are correct.

Correct clock configuration is necessary for proper operation of converters and for best sound quality. Make 1st Mytek in the chain the clock master for the whole studio. There is no benefit of using a dedicated house clock generator. Clocking off Mytek internal clock generator produces superior results because the clock and clock line high current drivers are the best in the industry.

Changing external synchronization source while the program is running may result in improper operation of converters and loud cracks in the analog section.

Input Connection

The Protools DIO-HD card features two connectors: *Primary Port* and *Expansion Port*. Functionality of these connectors is identical to Pro Tools system. Up to 8 8X192 ADDA Mytek Digital converters can be daisy chained or mixed with Digidesign HD-192 and other brands that emulate an HD-192.

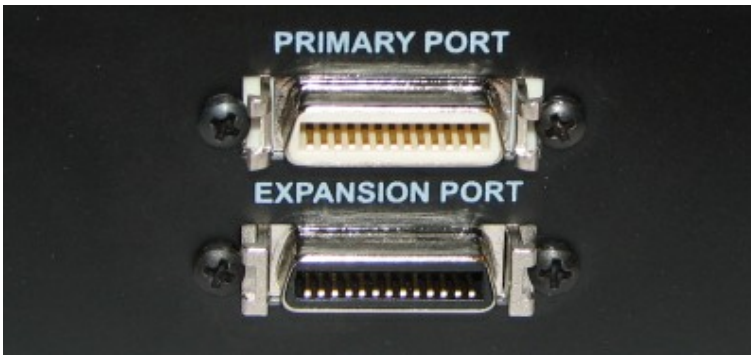

Output connectors on the back of Ptools-HD-DIO card.

Protools computer interface card should always be connected to the *Primary Port* in the *Master* device, which operates as a clock signal source. Then, *Expansion Port* can be connected with *Primary Port* of a different *Slave* device. Devices are visible in *Setup > Hardware Setup* menu of the Pro Tools application.

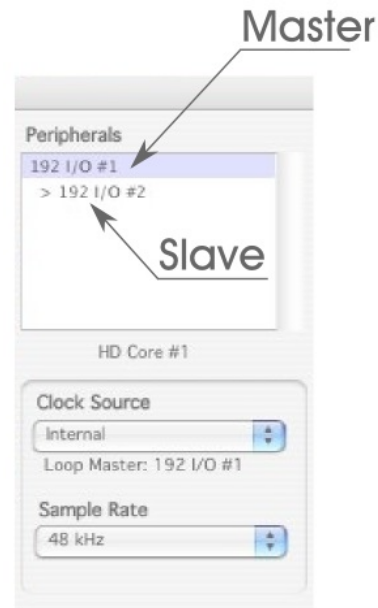

Setup > Hardware Setup

Signal Routing

While Protools software allows for up to 16 channels of input or output, only 8 inputs and outputs are active when Mytek 8X192 ADDA is used.

Input

Audio signals transmitted from the 8X192 ADDA converter originate from the source selected by the switch *SOURCE TO DIGITAL OUT*. If *ANALOG* is selected, 8 analog channels will show up as inputs in Protools software. If *AES/EBU* is selected, 8 digital channels will be present as inputs (only 4 if dual wire AES/EBU mode is used!). Similarly other types of digital inputs depending on the second DIO CARD2 installed can also be used. If DIO CARD1 is selected as input, signal output from Protools will be routed back into Protools inputs. The actual signal flow in the 8X192ADDA is available in a form of schematics in the 8X192ADDA manual.

After selecting channel sources in the converter, you can choose channels selected for recording in the Pro Tools application. In *Setup > I/O Setup* you can freely assign track sources to each interface channels and then assign them to particular tracks.

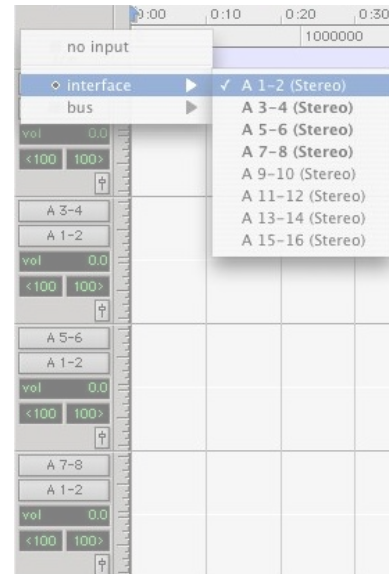

Editing panel - selecting input interfaces

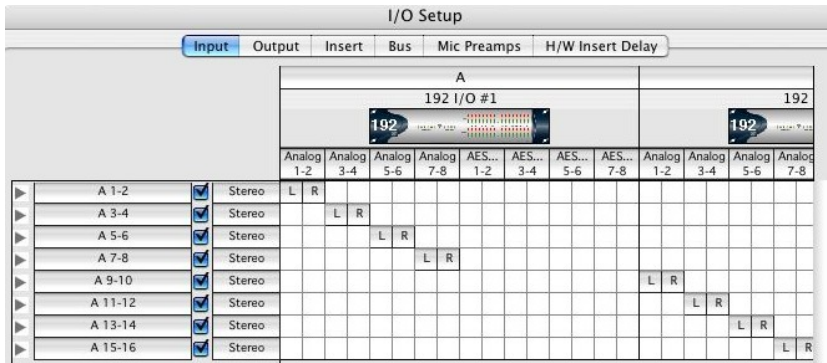

Setup > I/O Setup

Output

To playback signal from Protools to the converter's analog outputs *DIOCARD 1 SOURCE TO ANALOG OUT* should be selected. If *SOURCE TO DIGITAL OUT* is set to *DIOCARD1* as well audio is relayed from the Pro Tools system to the converter DAC (analog out) and to AES/EBU outputs as well as other digital outputs if installed.

The actual signal flow in the 8X192ADDA is available in the form of schematics in the 8X192ADDA manual.

The Protools tracks to be sent to the 8X192 ADDA can be selected in the ProTools software. In *Setup > I/O Setup* you can assign interfaces to signal outputs, later assigned to tracks in the Pro Tools application.

While track outputs are assigned to channels in the Protools software, the actual signal routing of the incoming 8 channels to the converter's physical inputs and outputs must be done manually on the converter front panel (*SOURCE TO ANALOG OUT* and *SOURCE TO DIGITAL OUT*). This routing may initially appear confusing, but after studying the signal flow diagram in the 8X192ADDA manual you will find it makes a lot of sense by providing very useful system flexibility.

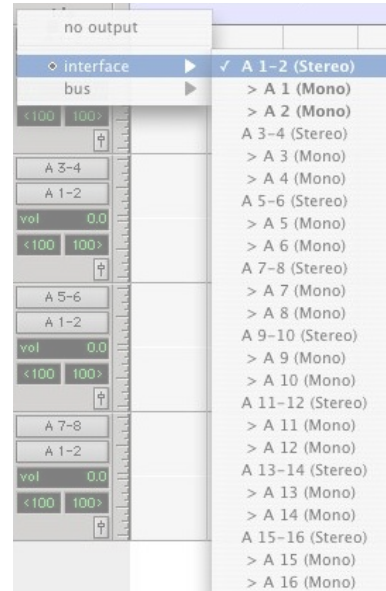

Editing panel - assigning output channels

Launch and Configuration

After the card installation in the converter, and after each hardware configuration change, interface controls must be configured in the Pro Tools application during the first launch. This is performed the following way:

1. Double check the cables connecting the converter with the Pro Tools card are properly attached.
2. Turn the converter on.
3. Check if clock signals are properly configured and active (solid lock, in case they are transmitted from an external device).
4. Launch the Pro Tools application.
5. In *Setup > Hardware Setup* check if attached converters were properly detected. 8X192 ADDA Mytek Converter with Protools DIO-HD card is detected as 192/IO in the Pro Tools system.

When the Pro Tools application is running do not turn the converter on or off. Always quit the application before turning off converter.

Take special precautions and turn down the output or volume to the amplifier and speakers while launching the ProTools application.



Setup > Hardware Setup

6. Select each converter and press *Set to Default* to set the application in the normal work mode.
7. In *Setup > I/O Setup* configure the routing according to your needs, while keeping in mind the 8X192 ADDA converter has only eight channels.

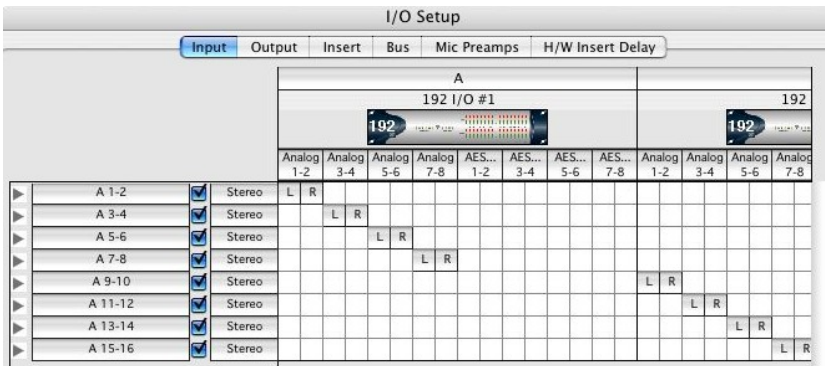

Setup > I/O Setup

If the converter is not attached to the Pro Tools systems, it can be used as a standalone device as if no DIO-HD card was installed. The DIO-HD card is disabled until it is connected to the Pro Tools systems and the application is launched on a computer.

When the application is launched, control over converter's sampling frequency is assigned to software. It is the only available option in *Setup > Hardware Setup* which influences converter's configuration. Other settings, such as selection of input or format of digital signal are ignored and should not be changed. Before launching the application pay special attention to clock signal source setting in the converter.

Remember that 8x192 ADDA converter has eight channels. Selecting channels 9-16 as audio sources will result in no signal (silence).



Setup > Hardware Setup

Typical Configurations

Single 8x192 ADDA converter

1. Connect the 8X192 ADDA (through *Primary Port*) to the Pro Tools interface card in a computer.
2. Turn on the computer and converter.
3. Set the converter to work with internal clock.
 - ✓ EXT LED shouldn't be lit.
 - ✗ If LED is lit, press and hold *EXT CLOCK SOURCE* button.
4. Launch the Pro Tools application.
5. Open *Setup > Hardware Setup* and check:
 - ✓ Is the 8X192 ADDA Mytek Digital converter properly detected as *192 I/O*?
 - ✓ Are input and output signals assigned in the *Input* and *Output* tab?
 - ✗ If not, close the Pro Tools application, turn off the converter and check connection between the HD-DIO card and the computer.



Setup > Hardware Setup

6. If hardware configuration was changed, open *Setup > Hardware Setup* and press *Set To Default*.
7. Set *Clock Source* as *Internal*.
8. Open or create new project with a chosen frequency.
 - ✓ LED indicating operation on the chosen frequency should lit on the front panel of the converter.
 - ✗ If LED is not lit or other frequency is indicated, check the connection between the DIO-HD card and the computer.
9. Use *SOURCE TO DIGITAL OUT* and *SOURCE TO ANALOG OUT* buttons to set the correct signal flow in the system.
 - ✓ Use *SOURCE TO DIGITAL OUT* button to select audio signals relayed from the 8X192 ADDA converter to the Pro Tools system and converter’s digital outputs.
 - ✓ Use *SOURCE TO ANALOG OUT* to select signals relayed to converter’s analog outputs.
10. In *Setup > I/O Setup* configure the routing according to your needs, keeping in mind that the 8X192 ADDA converter has eight channels.



File > New Session

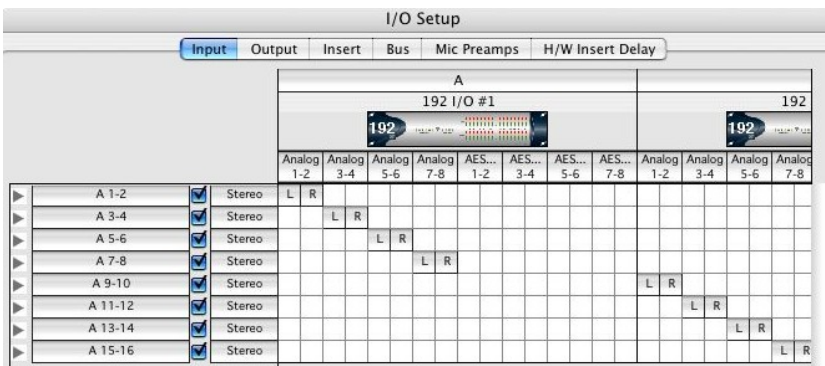

Setup > I/O Setup

11. In the editing panel assign input and output channels according to the *I/O Setup* configuration and converter's front panel.

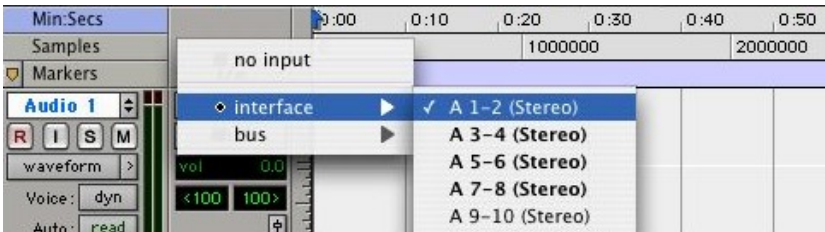

Editing panel – selecting input interfaces

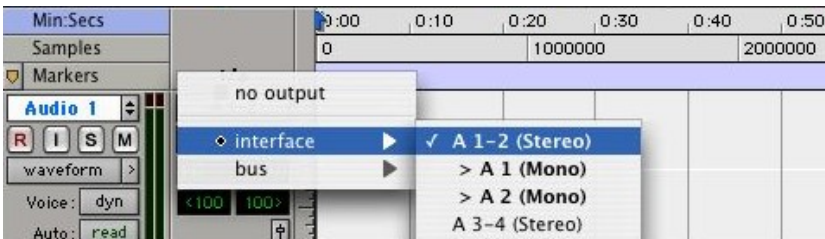

Editing panel – selecting output interfaces

12. The converter is ready to work.

Two 8x192 ADDA converters, first on internal clock (clock master), second as slave

1. Connect 8X192 ADDA converters to the Pro Tools card in a computer.
 - ✓ Computer should be connected to the *Primary Port* of the first converter, while its *Expansion Port* should be connected to the *Primary Port* of the second converter.
2. Choose which converter will operate as a clock signal source (*Master*).
3. Use a BNC cable to connect the clock signal output of the *Master converter* to the clock input of the second converter (*Slave*).
4. Turn on the computer and converters.
5. Set the *Master* converter to work with internal clock.
 - ✓ EXT LED should not be lit.
 - x If LED is lit, press and hold *EXT CLOCK SOURCE button*.
6. Set the *Slave* converter to work with the external clock.
 - ✓ Press and hold the *EXT. CLOCK SOURCE button*.
 - x If EXT LED is lit and WCK LED flashes, check if clock inputs and outputs in converters were correctly connected and the same *SAMPLE RATE* sampling frequency and *WCK* frequency split rate is set in both converters.
7. Launch the Pro Tools application.

8. Open *Setup > Hardware Setup* and check:
 - ✓ Are 8X192 ADDA Mytek Digital/EBU converters properly detected as *192 I/O*?
 - ✓ Are signals input and output of each converter assigned in the *Input* and *Output* tab?
 - ✗ If not, turn off the Pro Tools application and converters and check the connections of clock signals between converters as well as the connections between DIO-HD cards and with computer.

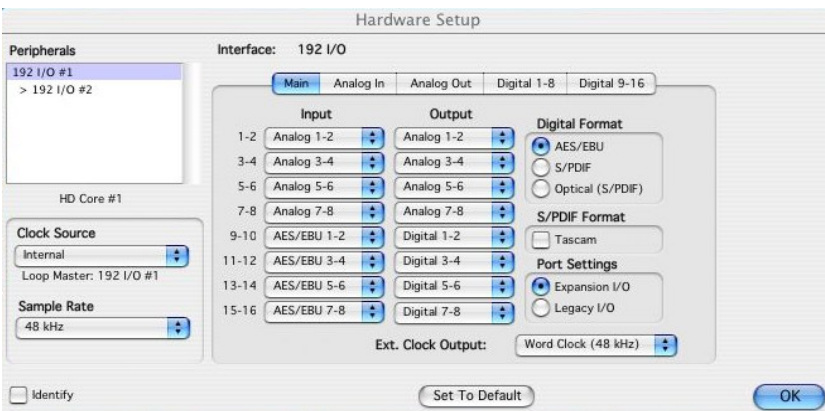

Setup > Hardware Setup

9. If the hardware configuration was changed, open *Setup > Hardware Setup* and press *Set To Default*.

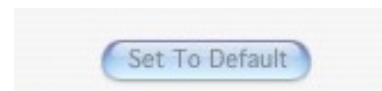

10. Set *Clock Source* as *Internal*.
11. Open or create new project with a chosen frequency.
 - ✓ LED indicating operation at the chosen frequency should be lit on the front panel.
 - ✗ If LED is not lit or another frequency is indicated, check the connection between DIO-HD cards and with the computer.

12. Use *SOURCE TO DIGITAL OUT* and *SOURCE TO ANALOG OUT* buttons to set desired signal flow in the system.
 - ✓ Use *SOURCE TO DIGITAL OUT* button to select which audio signals are sent from the 8X192 ADDA converter to the Pro Tools system and converter’s digital outputs.
 - ✓ Choose the signal transmitted to converter’s analog output by pressing *SOURCE TO ANALOG OUT* button.

13. In *Setup > I/O Setup* configure the routing according to your needs, keeping in mind that 8X192 ADDA converter has eight channels.

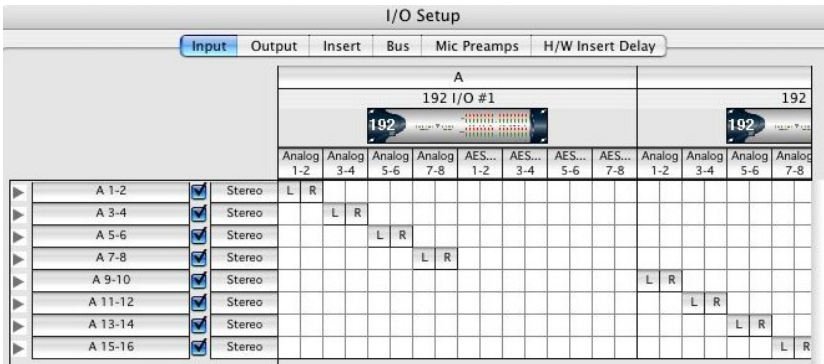

Setup > I/O Setup

14. In the editing panel assign input and output channels, according to the *I/O Setup* configuration and converter's front panel.

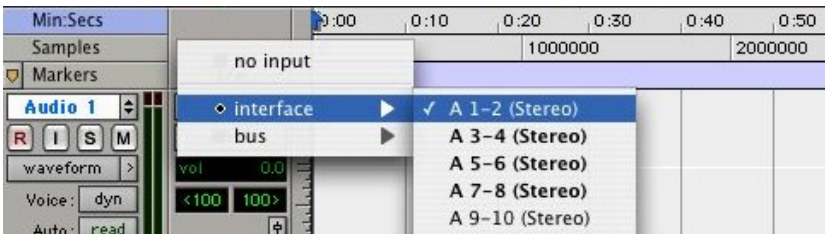

Editing panel – selecting input interfaces

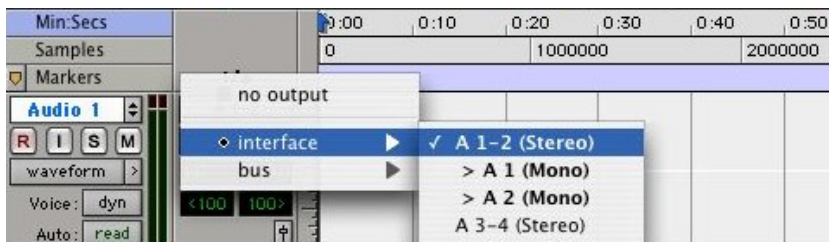

Editing panel – selecting output interfaces

15. Converters are ready to work

Software update

WARNING!

Remember to follow basic safety rules about the handling of electronic devices while opening the converter:

- ✓ keep your hands dry,
- ✓ **remember to turn off power and disconnect power and signal cables** while working with the top cover removed.

To perform firmware update of 8X192 ADDA converter:

1. Check if the power cord and signal and clock lines are disconnected.
2. Remove the top cover.



3. Locate the memory socket on the converter main board.

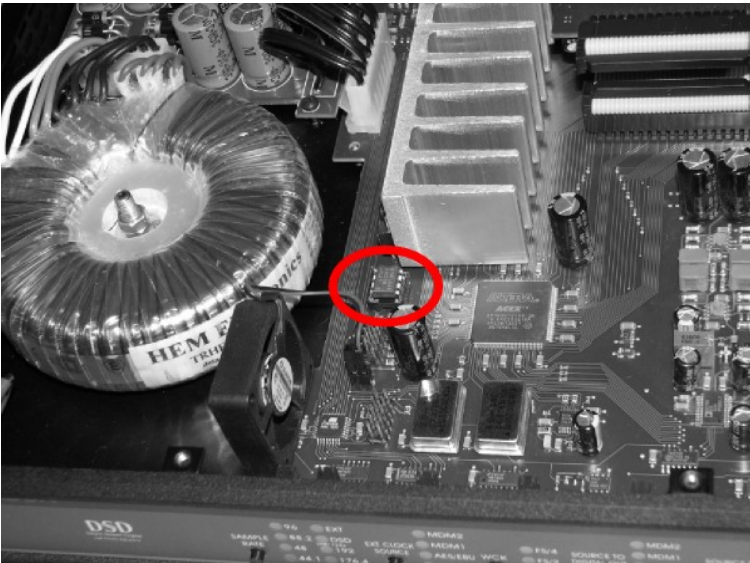

4. Gently remove old memory chip.

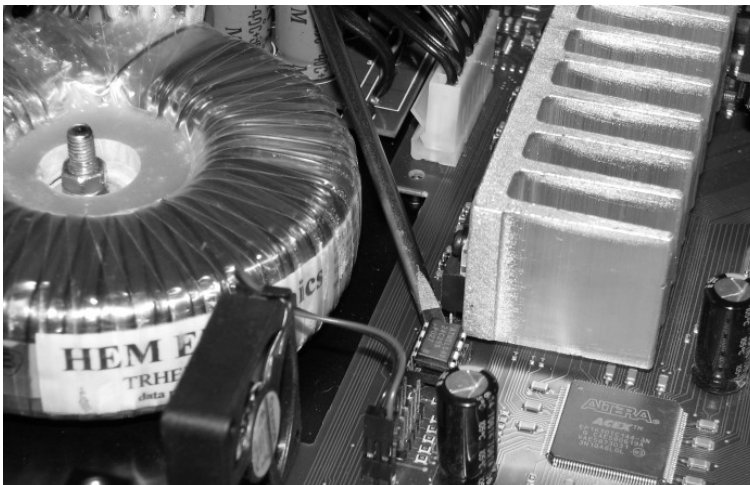

To avoid damaging memory pins, remove the chip vertically. Retain old memory chip.

- Carefully insert new memory chip in the socket. The chip slot (pin1) should be matching the socket slot it must be facing back of the unit. If necessary gently manually bend pins inward, to match the holes in the slot.

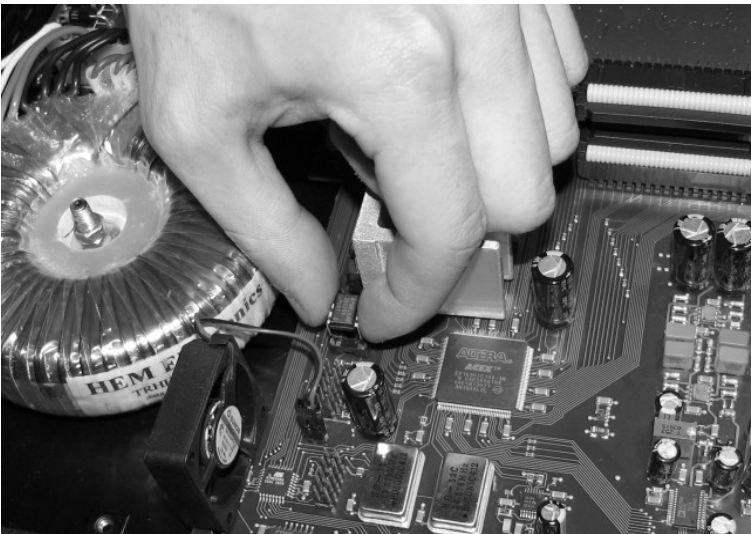

During installation check correct chip orientation.

- Mount the top cover back.

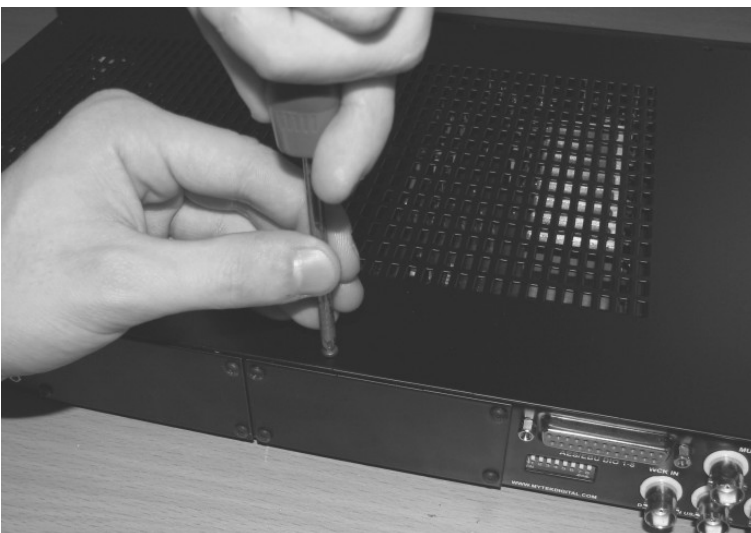

7. Attach power cord and other cabling.
8. Turn on the converter.

For about 2 seconds no LED's should be lit on the converter's front panel, as new software is copied from memory to the main board chips. Then, all LED's should turn on momentarily for about 10-20sec, and subsequently the unit should begin normal operation.

The Protools HD DIO card also contains a similar EPROM memory chip that may require future upgrades should such a need arise due to Protools software revisions or implementation of additional features.

Check Mytek webpage for information on the latest firmware versions.

www.mytekdigital.com